

HC 09 S



I MIGLIORI PRODOTTI DI QUALITÀ | BEST QUALITY PRODUCTS

www.hcindustrie.com

HC 09 S	A1	A2	A3
MOMENTO DI SOLLEVAMENTO LIFTING MOMENT - MOMENT DE LEVAGE - MOMENTO DE ELEVACIÓN	kNm 10,5	kNm 10,5	kNm 10,5
MASSIMO CARICO SOLLEVABILE MAX. LIFTING CAPACITY - PUISSANCE DE LEVAGE - CARGA ÚTIL MÁXIMA	kg 990	kg 990	kg 990
MASSIMO SBRACCIO IDRAULICO MAX. HYDRAULIC OUTREACH - PORTÉE HYDRAULIQUE MAXIMALE - ALCANCE HIDRÁULICO MÁXIMO	m 1,77	m 2,67	m 3,41
ANGOLO MASSIMO DI ROTAZIONE SLEWING ANGLE - ANGLE DE ROTATION - GIRO MÁXIMO	330°	330°	330°
COPPIA DI ROTAZIONE SLEWING TORQUE - COUPLE DE ROTATION - PAR DE GIRO	kNm 1,5 (0,15 tm)	kNm 1,5 (0,15 tm)	kNm 1,5 (0,15 tm)
PRESSIONE MASSIMA DI LAVORO OPERATING PRESSURE - PRESSION D'UTILISATION - PRESIÓN DE SERVICIO	Mpa 19,0 (190 bar)	Mpa 19,0 (190 bar)	Mpa 19,0 (190 bar)
PORTATA D'OLIO CONSIGLIATA RECOMMENDED PUMP CAPACITY - DÉBIT DE POMPE RECOMMANDÉ - CAUDAL DE ACEITE RECOMENDADO	l/min. 6	l/min. 6	l/min. 6
MASSA DELLA GRU STANDARD STANDARD CRANE MASS - MASSE DE LA GRUE STANDARD - PESO DE LA GRUA STANDARD	kg 135	kg 150	kg 180

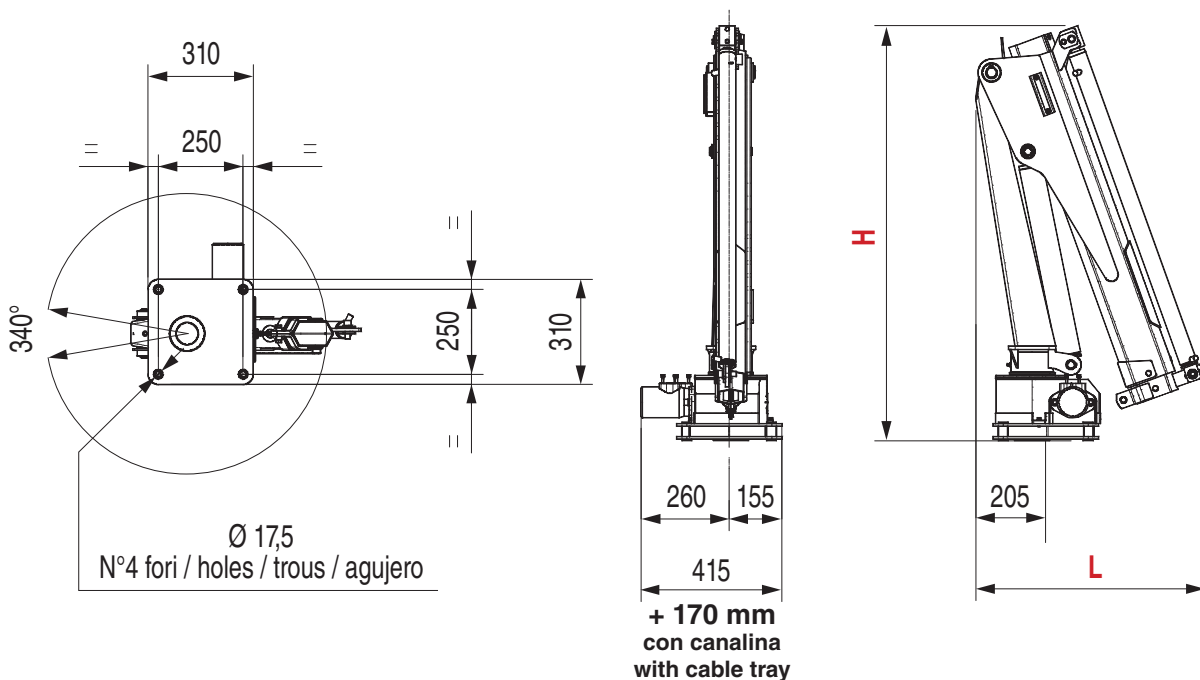

	HC 09 S A1	HC 09 S A2	HC 09 S A3
L	mm 677	mm 695	mm 695
H	mm 1222	mm 1222	mm 1226

HC 09 S A1 + P2 + P3 + P4

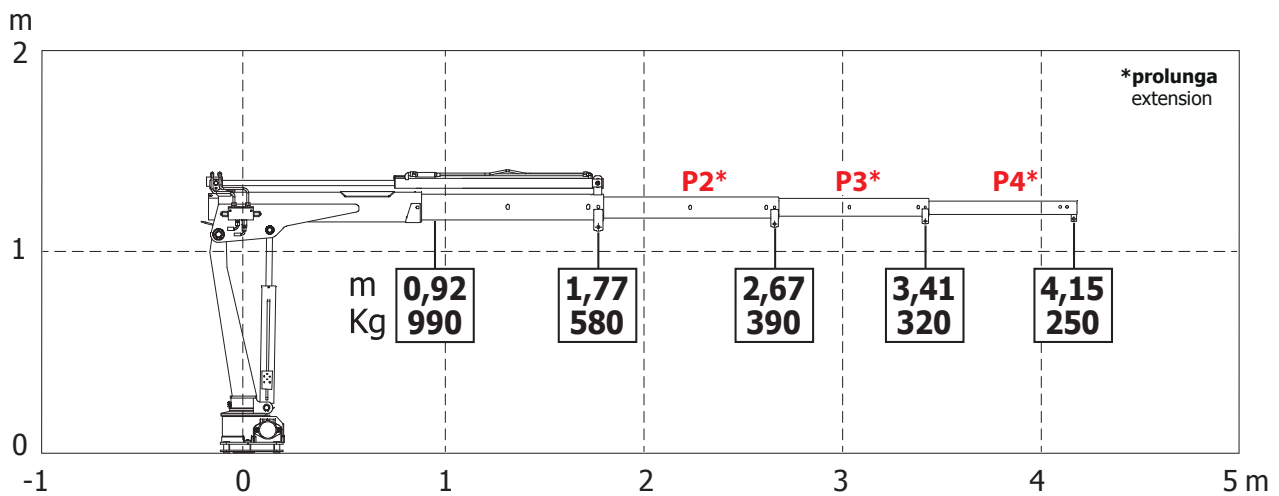

HC 09 S A2 + P3 + P4

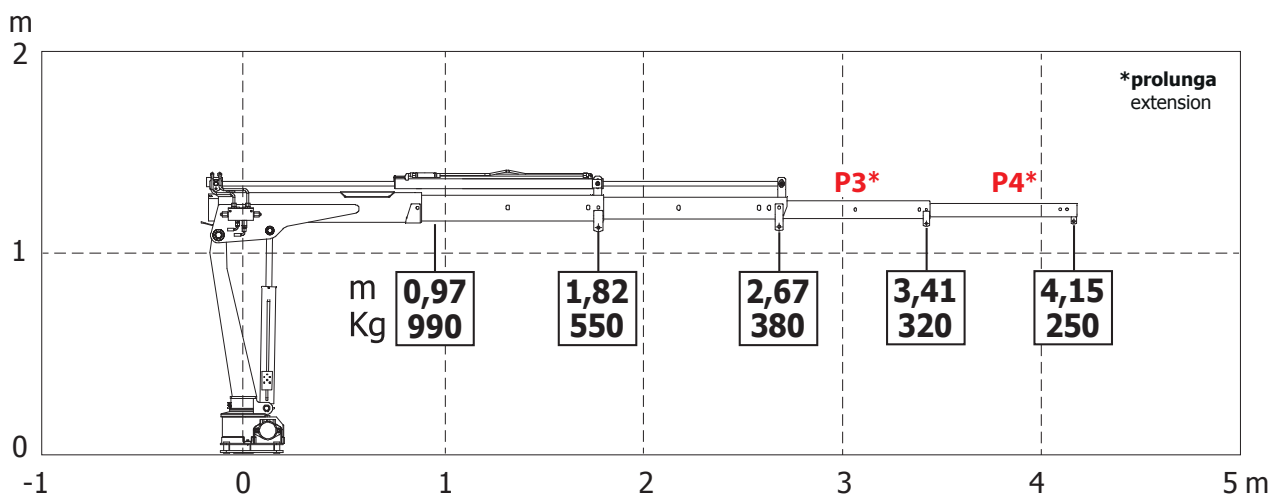

HC 09 S A3 + P4

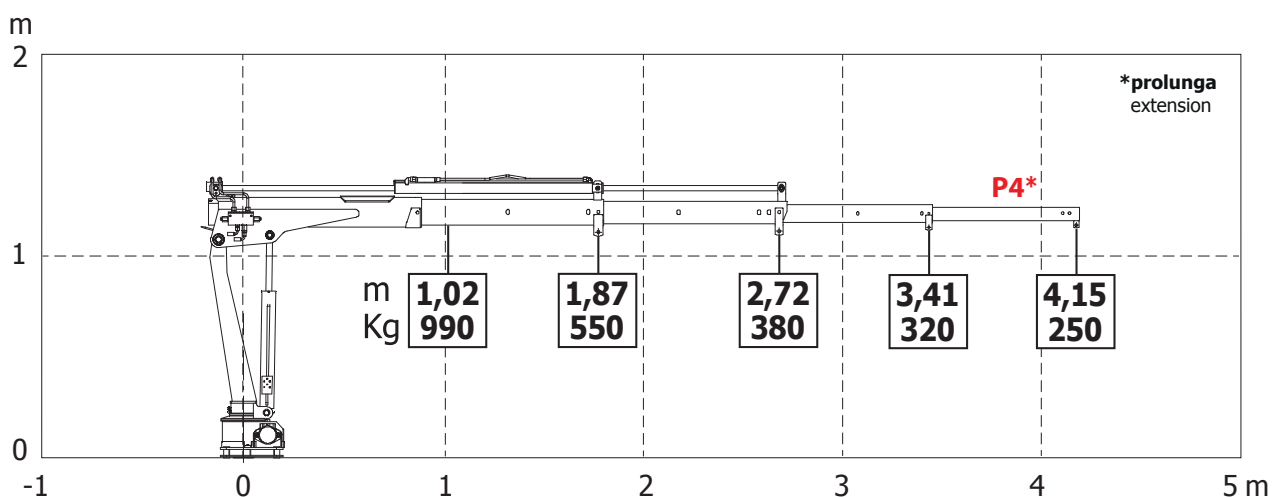

OPTIONAL

BASAMENTO CON STABILIZZATORI - BASEMENT WITH STABILIZERS - CADRE D'ASSEMBLAGE AVEC STABILISATEURS - PLACA DE APOYO CON ESTABILIZADORES

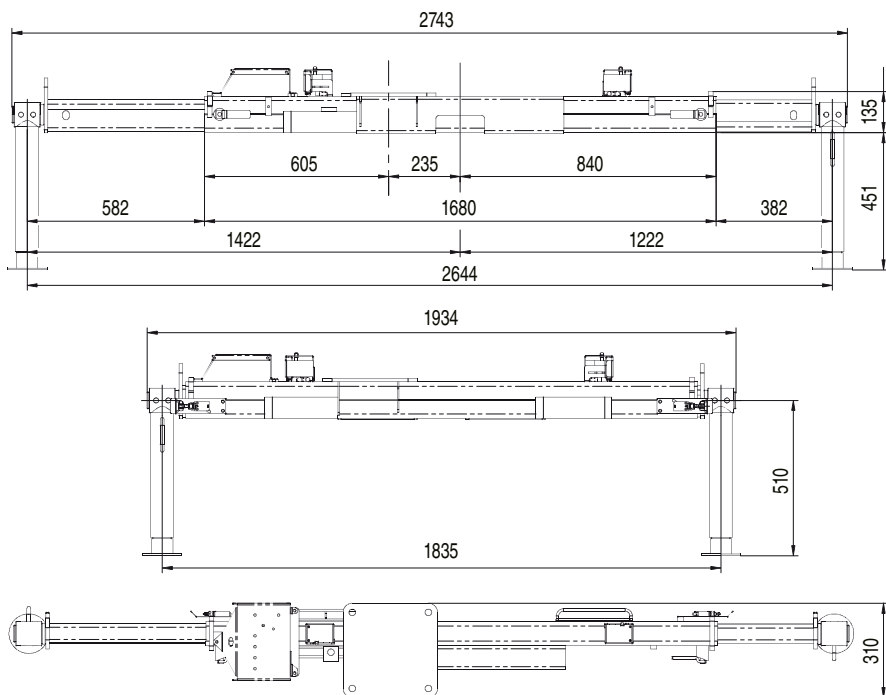

VERSIONE CON CILINDRI STABILIZZATORI MANUALI

VERSION WITH MANUAL STABILIZING CYLINDERS



kg 79

VERSION VERINS STABILISATEURS MANUELS

VERSIÓN CON CILINDROS ESTABILIZADORES MANUALES

VERSIONE CON CILINDRI STABILIZZATORI IDRAULICI GIREVOLI

VERSION WITH HYDRAULIC ROTATING STABILIZING CYLINDERS

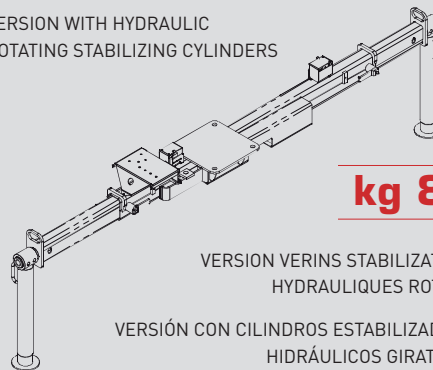

kg 85

VERSION VERINS STABILISATEURS HYDRAULIQUES ROTATIFS

VERSIÓN CON CILINDROS ESTABILIZADORES HIDRÁULICOS GIRATORIOS



BASE ASTA LATERALE

Side stab holder
40 Kg



POMPA ELETTROIDRAULICA

Power pack
1600 W

CENTRALINA

Power unit



3000 W
elettroidraulica
electro-hydraulic

ASTA MAX

Extra stab



STABILIZZATORE EXTRA

STABILIZZATORE EXTRA - EXTRA STABILIZER - STABILISATEUR EXTRA - ESTABILIZADOR EXTRA



TUTTI I DATI TECNICI POSSONO ESSERE CAMBIATI SENZA PREAVVISO - ALL TECHNICAL DATA CAN BE CHANGED WITHOUT NOTICE
TOUS LES DONNEES TECHNIQUES PEUVENT ETRE MODIFIEES SANS PREAVIS - TODOS LOS DATOS TECNICOS PUEDEN SER CAMBIADOS SIN AVISO

HC INDUSTRIE S.R.L.

Via Luciano Romagnoli, 1

42023 Cadelbosco di Sopra Reggio Emilia, Z.I. La Madonnina (RE)

Phone +39.0522.911729 - Fax +39.0522.404040

Email: commerciale@hcindustrie.com - Website: www.hcindustrie.com